



Demonstration

For Perfect Long Threads on Swiss Type Machines

- Single pass working ability reduces machining time and increases productivity
- A high accuracy Holder-Insert system along with special cutting edge geometry leads to a high quality surface finish
- Multi-Insert holders reduce cycle time and increase tool life
- Whirling toolholders consist of 6 to 8 inserts
- Whirling inserts consist of three cutting edges with high indexability
- Whirling inserts can produce single or double start threads in one pass

Contents:

Thread Whirling Advantages
Applications
Product Identification

Page:

2
2
3

Contents:

Case Study
Specials

Page:

4
4

Thread Whirling is a fast and an accurate way to thread long, small diameter parts in exotic materials such as titanium, stainless steel and inconel.

Cutting is the result of the whirling ring rotating eccentrically at high speed about the slowly rotating workpiece. The advancement of the workpiece rotationally and the advancement of the tool head longitudinally correspond to the thread pitch required.

Advantages

Thread Whirling offers several advantages over single point threading:

Enables production of small diameter long threads when used on Swiss type machines. The thread whirling spindle works close to the guide bushing for increased support and rigidity.

Increased Productivity

Thread Whirling is performed in a single pass, resulting in a shorter machining time.

This eliminates multiple passes required for a single point threading.

Thread whirling allows working at high feed rates and consequently results in short cycle times.

Very high surface quality and accurate geometry

The use of 6 to 8 cutting edges, higher concentricity, special cutting edge geometry and ideal chip removal, enable top quality surfaces to be produced without burrs.

Long tool life

Whirling inserts have a stronger cutting edge than single point tools, since cutter side clearance is achieved by rotating the whirling spindle, not by relieving material under the cutting edge.

Faster Setup

Thread whirling eliminates special support devices and expensive startup development costs.

Compensation of large helix angles

Large helix angles can be compensated by adjusting the whirling unit.

Short Delivery Time

Up to 3 weeks.

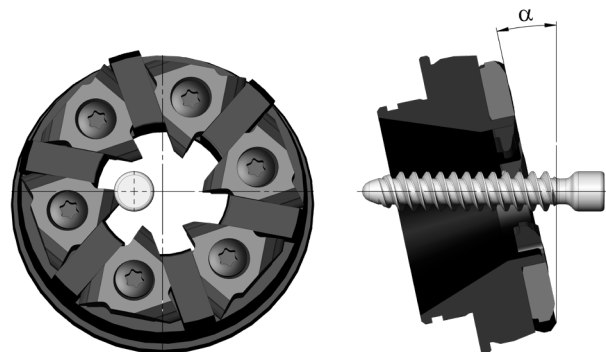

Applications

CPT supports and offers high quality Thread Whirling tools for a wide range of applications, such as: Bone screws, Dental implants, Orthopedic screws, automotive parts, semiconductor small parts, etc.

CPT holds in stock thread whirling holders that are compatible with all

Swiss Type machines such as STAR, Citizen, Tornos, Hanwha, Tsugami, Nexturn, and **Whirling units** as PCM, WTO, H&F, MADAULA, etc.

Machine details and **Whirling unit** details are needed in order to offer a suitable toolholder.

Machine		Whirling Unit	Whirling Holder Ordering Code	Z	D	d1	Insert Size
Type	Model						
Star	SR20 / ECAS20	Star	SRW4012 730 - 6	6	12	40	18W
			SRW4012 425 - 8	8			11W
	SR20 / ECAS20	WTO	SRW4295 557 - 6	6	9.5	42	18W
			SRW4212 717 - 8	8	12	42	11W
Citizen	M20 / M32	PCM	SRW4512 719 - 6	6	12	45	18W
			SRW4512 427 - 8	8			11W

* The above table serves as an example.



Product Identification - Ordering Codes

Toolholders

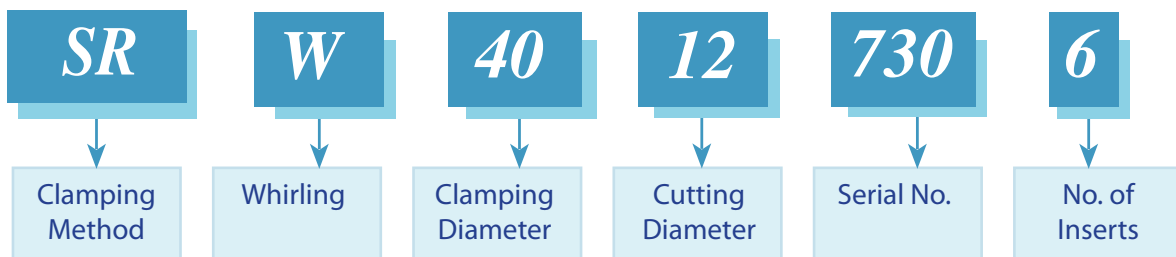

Inserts

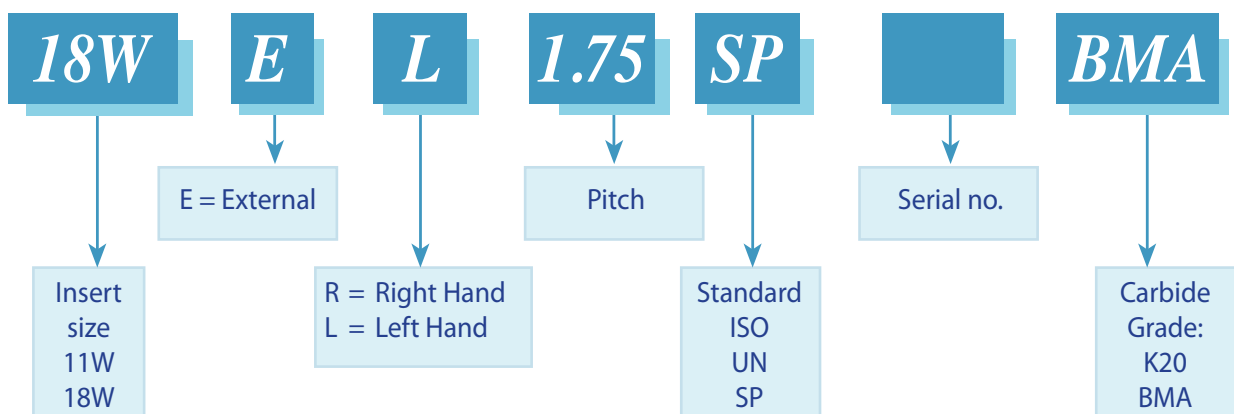

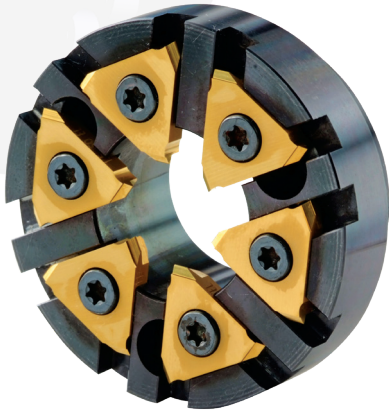

Case Study

Machine:	STAR SR20
Whirling unit:	STAR
Application:	Dental Implant
Material:	Ti-6Al-4V ELI
CPT holder:	SRW4012 730-6
Vc [m/min]:	65
Tooth load [mm/tooth]:	0.03
No. of parts:	25,000 +



SPECIALS ARE OUR SPECIALTY

CPT produce special tools in accordance with the customer's requirements

