



Your technology partner for cost-effective machining

UNIQ[®] – the new generation
of hydraulic expansion technology

INDUSTRIAL DESIGN WITH ADDED VALUE – UNIQ® CHUCK

The newly-developed hydraulic clamping system enables high machining parameters through excellent stability and accuracy. It minimises self-excited vibration so that clamped tools are not exposed to micro-vibration. This in turn leads to a reduced spindle load of up to 5 percent, enables a significantly longer tool life and guarantees optimal surface quality.

In addition, the brilliant surface which MAPAL creates using a specially developed polishing process ensures that the chucks are more resistant to dirt and corrosion. Users can safely clamp the tool in the holder with little force requirement. This is ensured by "foolproof handling", i.e. simple and self-explanatory handling of the chucks. This saves a considerable amount of time compared to other clamping mechanisms, especially with the Hydro DReaM Chuck 4.5°.



Design features in detail:

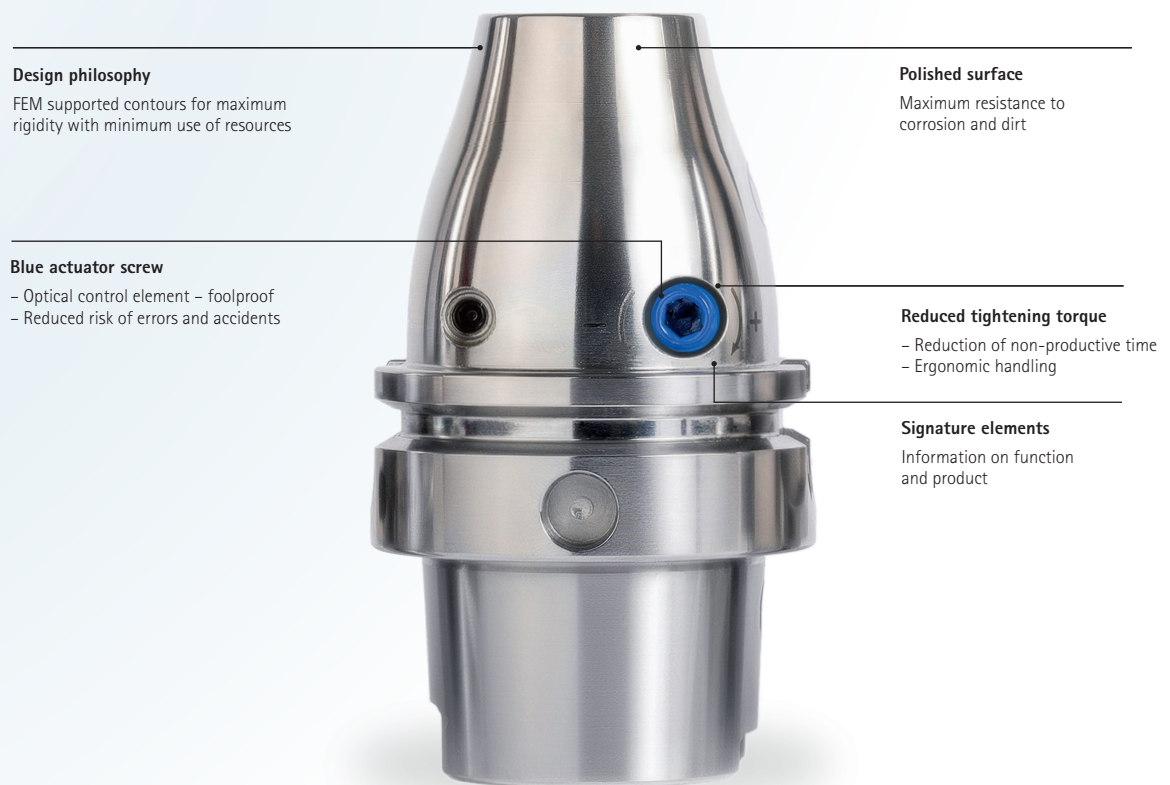

Formal language – Bionic contours

- Higher stability and accuracy of the overall system
- Less displacement of the tool
- The tool cutting edge is constantly in intervention
- Less weight due to minimal use of resources
- Fits well in the hand when setting up the tool magazine
- Self-excited vibrations are minimized
- The tools are not exposed to micro vibrations

Polished surfaces

- Dirt resistance (corrosion resistance) increased
- Highest balancing qualities due to compacted surfaces

Blue actuation screw | Signature Elements

- Clear assignment of the operating screw and easier actuation by reducing the up to 70 % reduced tightening torque of the operating screw
- Clarity of the product created, important functional and product information immediately available

UNIQ® Mill Chuck, HA

With axial tool length adjustment

Shank hollow shank taper A according to DIN 69893-1

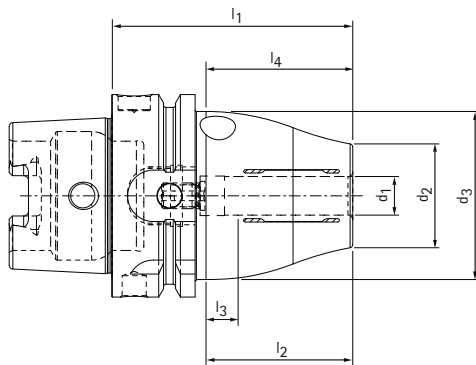

HSK-A	Dimensions							G	Torque * [Nm]	Specification	Order No.	Availability
	d_1	d_2	d_3	l_1	l_2	l_3	l_4					
63	6,0	26,0	50,0	65,0	37,0	10,0	35,2	M5	22	MHC-HSK-A063-06-065-1-0-A	31270591	in stock
63	8,0	28,0	50,0	65,0	37,0	10,0	35,2	M6	47	MHC-HSK-A063-08-065-1-0-A	31270593	
63	10,0	30,0	50,0	75,0	41,0	10,0	45,2	M8x1	85	MHC-HSK-A063-10-075-1-0-A	31270595	
63	12,0	32,0	52,5	75,0	46,0	10,0	45,2	M8x1	130	MHC-HSK-A063-12-075-1-0-A	31229418	
63	14,0	34,0	52,5	75,0	46,0	10,0	45,2	M8x1	240	MHC-HSK-A063-14-075-1-0-A	31374670	
63	16,0	38,0	52,5	79,0	49,0	10,0	49,2	M8x1	350	MHC-HSK-A063-16-079-1-0-A	31270598	
63	18,0	38,0	52,5	79,0	49,0	10,0	49,2	M8x1	430	MHC-HSK-A063-18-079-1-0-A	31374671	
63	20,0	38,0	52,5	79,0	51,0	10,0	49,2	M8x1	520	MHC-HSK-A063-20-079-1-0-A	31229438	
63	25,0	48,0	57,0	95,0	57,0	10,0	45,0	M10x1	700	MHC-HSK-A063-25-095-1-0-A	31396170	
63	32,0	58,5	62,5	110,0	61,0	10,0	56,6	M10x1	900	MHC-HSK-A063-32-110-1-0-A	31396171	
100	6,0	26,0	50,0	73,0	37,0	10,0	40,2	M5	22	MHC-HSK-A100-06-073-1-0-A	31345192	in stock
100	8,0	28,0	50,0	73,0	37,0	10,0	40,2	M6	47	MHC-HSK-A100-08-073-1-0-A	31345193	
100	10,0	30,0	50,0	83,0	41,0	10,0	50,2	M8x1	85	MHC-HSK-A100-10-083-1-0-A	31345194	
100	12,0	32,0	52,5	83,0	46,0	10,0	50,2	M8x1	130	MHC-HSK-A100-12-083-1-0-A	31345195	
100	14,0	34,0	52,5	83,0	46,0	10,0	50,2	M8x1	240	MHC-HSK-A100-14-083-1-0-A	31345196	
100	16,0	38,0	52,5	87,0	49,0	10,0	54,2	M8x1	350	MHC-HSK-A100-16-087-1-0-A	31345197	
100	18,0	38,0	52,5	87,0	49,0	10,0	54,2	M8x1	430	MHC-HSK-A100-18-087-1-0-A	31345198	
100	20,0	38,0	52,5	87,0	51,0	10,0	54,2	M8x1	520	MHC-HSK-A100-20-087-1-0-A	31345199	
100	25,0	56,0	70,0	95,0	57,0	10,0	62,2	M10x1	700	MHC-HSK-A100-25-095-1-0-A	31345200	
100	32,0	60,0	75,0	100,0	61,0	10,0	67,2	M10x1	900	MHC-HSK-A100-32-100-1-0-A	31345201	

* Permissible transmittable torque.

Dimensions in mm.

Application: For clamping tools with smooth cylindrical shanks to DIN 1835 Form A, DIN 6535 Form HA as well as with recesses to DIN 1835 Form B, E and DIN 6535 Form HB, HE directly and with reducing sleeve in the clamping diameter. The clamping diameter is designed for a shank tolerance h6.

Scope of delivery: With length adjustment screw, without coolant tube.

Design: Highest tool life and production quality when using smooth shanks according to DIN 1835 form A and DIN 6535 form HA.

With a length of 2.5xD (max. 50 mm) concentricity 3 μ m. When using cylindrical shanks

with inclined clamping surface (form E and form HE), the accuracy may be impaired.

Torque transmission perfectly tailored to your application.

Note: Coolant supply via central through hole. Coolant tubes, code carriers, reducing sleeves for reducing the clamping diameter (when using the reducing sleeve, an impairment of the accuracy is possible) see category accessories, spare parts and measuring equipment. Length adjustment screws available on request.

Balance quality: G 2.5 at 25,000 min^{-1} as delivered.

UNIQ[®] Mill Chuck, HA

With axial tool length adjustment

Shank hollow shank taper A according to ISO 7388-1 form AD/AF

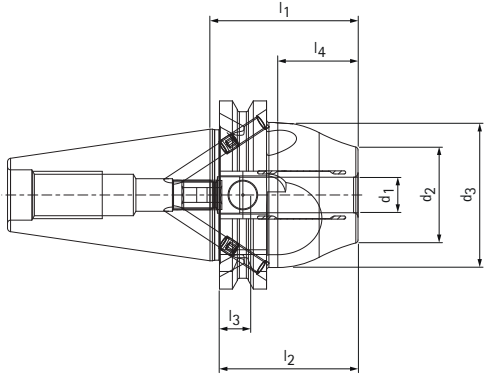

SK	Dimensions								G	Torque* [Nm]	Specification	Order No.	Availability
	d ₁	d ₂	d ₃	d ₄	l ₁	l ₂	l ₃	l ₄					
40	6,0	26,0	42,0	-	50,0	37,0	10,0	27,1	M5	22	MHC-SK040-06-050-3-0-A	31345212	in stock
40	8,0	28,0	42,0	-	50,0	37,0	10,0	27,1	M6	47	MHC-SK040-08-050-3-0-A	31345213	
40	10,0	30,0	42,0	-	50,0	41,0	10,0	27,1	M8x1	85	MHC-SK040-10-050-3-0-A	31345214	
40	12,0	32,0	49,0	-	50,0	46,0	10,0	27,1	M10x1	130	MHC-SK040-12-050-3-0-A	31345215	
40	14,0	34,0	49,0	-	50,0	46,0	10,0	27,1	M10x1	240	MHC-SK040-14-050-3-0-A	31374686	
40	16,0	38,0	49,0	-	64,5	49,0	10,0	41,6	M12x1	350	MHC-SK040-16-065-3-0-A	31345216	
40	18,0	38,0	49,0	-	64,5	49,0	10,0	41,6	M12x1	430	MHC-SK040-18-065-3-0-A	31374687	
40	20,0	38,0	49,0	-	64,5	51,0	10,0	41,6	M16x1	520	MHC-SK040-20-065-3-0-A	31345217	
40	25,0	48,0	57,0	49,5	110,0	57,0	10,0	65,3	M10x1	700	MHC-SK040-25-110-3-0-A	31396178	
40	32,0	58,5	62,5	49,5	115,0	61,0	10,0	65,5	M12x1	900	MHC-SK040-32-115-3-0-A	31396179	

* Permissible transmittable torque.

Dimensions in mm.

Application: For clamping tools with smooth cylindrical shanks to DIN 1835 Form A, DIN 6535 Form HA as well as with recesses to DIN 1835 Form B, E and DIN 6535 Form HB, HE directly and with reducing sleeve in the clamping diameter. The clamping diameter is designed for a shank tolerance h6.

Scope of delivery: With length adjustment screw, without coolant tube.

Design: Highest tool life and production quality when using smooth shanks according to DIN 1835 form A and DIN 6535 form HA.

With a length of 2.5xD (max. 50 mm) concentricity 3 µm. When using cylindrical shanks

with inclined clamping surface (form E and form HE), the accuracy may be impaired.

Torque transmission perfectly tailored to your application.

Note: Coolant supply via central through hole. Coolant tubes, code carriers, reducing sleeves for reducing the clamping diameter (when using the reducing sleeve, an impairment of the accuracy is possible) see category accessories, spare parts and measuring equipment. Length adjustment screws available on request.

Balance quality: G 2.5 at 25,000 min⁻¹ as delivered.

UNIQ® Mill Chuck, HA

With axial tool length adjustment

Shank BT according to ISO 7388-2 form JD/JF (JIS B 6339)

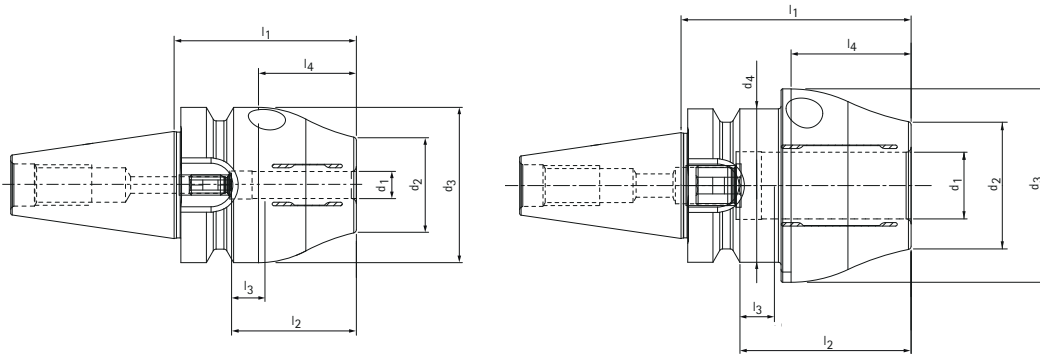

BT	Dimensions								G	Torque * [Nm]	Specification	Order No.	Availability
	d ₁	d ₂	d ₃	d ₄	l ₁	l ₂	l ₃	l ₄					
30**	6,0	26,0	46,0	–	54,0	37,0	10,0	29	M5	22	MHC-BT030-06-054-1-0-A	31280342	in stock
30**	8,0	28,0	46,0	–	54,0	37,0	10,0	29	M6	47	MHC-BT030-08-054-1-0-A	31280343	
30**	10,0	30,0	50,0	46,0	54,0	41,0	10,0	23,5	M8x1	85	MHC-BT030-10-054-1-0-A	31280344	
30**	12,0	32,0	50,0	46,0	54,0	46,0	10,0	23,5	M10x1	130	MHC-BT030-12-054-1-0-A	31280345	
30**	14,0	38,0	52,0	46,0	54,0	46,0	10,0	21,0	M10x1	240	MHC-BT030-14-054-1-0-A	31374678	
30**	16,0	38,0	55,0	46,0	69,0	49,0	10,0	38,5	M12x1	350	MHC-BT030-16-069-1-0-A	31280346	
30**	18,0	38,0	55,0	46,0	69,0	49,0	10,0	36,0	M12x1	430	MHC-BT030-18-069-1-0-A	31374679	
30**	20,0	38,0	58,0	46,0	69,0	51,0	10,0	38,5	M12x1	520	MHC-BT030-20-069-1-0-A	31280347	
40	6,0	26,0	42,0	–	58,0	37,0	10,0	27,2	M5	22	MHC-BT040-06-058-3-0-A	31345236	
40	8,0	28,0	42,0	–	58,0	37,0	10,0	27,2	M6	47	MHC-BT040-08-058-3-0-A	31345237	
40	10,0	30,0	42,0	–	58,0	41,0	10,0	27,2	M8x1	85	MHC-BT040-10-058-3-0-A	31345238	
40	12,0	32,0	49,0	–	58,0	46,0	10,0	27,2	M10x1	130	MHC-BT040-12-058-3-0-A	31345239	
40	14,0	34,0	49,0	–	58,0	46,0	10,0	27,2	M10x1	240	MHC-BT040-14-058-3-0-A	31396154	
40	16,0	38,0	49,0	–	72,5	49,0	10,0	41,7	M12x1	350	MHC-BT040-16-073-3-0-A	31345240	
40	18,0	38,0	49,0	–	72,5	49,0	10,0	41,7	M12x1	430	MHC-BT040-18-073-3-0-A	31396155	
40	20,0	38,0	49,0	–	72,5	51,0	10,0	41,7	M16x1	520	MHC-BT040-20-073-3-0-A	31345241	
40	25,0	48,0	57,0	–	100,0	57,0	10,0	44,6	M16x1	700	MHC-BT040-25-100-3-0-A	31396156	
40	32,0	58,5	62,0	–	105,0	61,0	10,0	50,0	M16x1	900	MHC-BT040-32-105-3-0-A	31396157	

* Permissible transmittable torque.

** Design: Steep taper size is not available in combined JD/JF version.

Dimensions in mm.

Application: For clamping tools with smooth cylindrical shanks to DIN 1835 Form A, DIN 6535 Form HA as well as with recesses to DIN 1835 Form B, E and DIN 6535 Form HB, HE directly and with reducing sleeve in the clamping diameter. The clamping diameter is designed for a shank tolerance h6.

Scope of delivery: With length adjustment screw, without tightening bolt.

Design: Highest tool life and manufacturing quality when using smooth shanks according to DIN 1835 form A and DIN 6535 form HA. With an overhang length of 2.5xD (max.

50 mm) concentricity accuracy 3 µm. When using cylindrical shanks with inclined clamping surface (form E and form HE), the accuracy may be impaired. Torque transmission perfectly tailored to your application.

Note: Coolant supply via central through hole. Tightening bolts, reducing sleeves for reducing the clamping diameter. (When using the reducing sleeve, accuracy may be impaired) see category accessories and spare parts. Length adjustment screws available on request. Balance quality: G 2.5 at 25,000 min⁻¹ as delivered.

UNIQ[®] Mill Chuck, HA

With axial tool length adjustment

Shank "CAT" according to ASME B5.50-1994

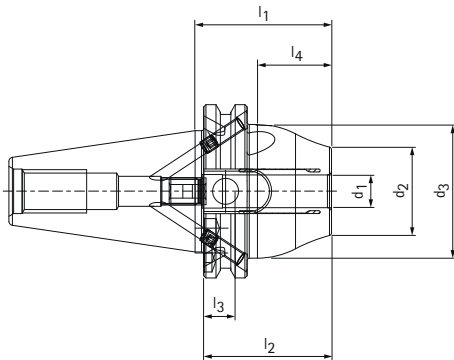

CAT	Dimensions							G	Torque * [Nm]	Specification	Order No.	Availability
	d_1	d_2	d_3	l_1	l_2	l_3	l_4					
40	6,0	26,0	42,0	50,0	37,0	10,0	27,1	M5	22	MHC-CAT040-06-050-3-0-A	31345224	in stock
40	8,0	28,0	42,0	50,0	37,0	10,0	27,1	M6	47	MHC-CAT040-08-050-3-0-A	31345225	
40	10,0	30,0	42,0	50,0	41,0	10,0	27,1	M8x1	85	MHC-CAT040-10-050-3-0-A	31345226	
40	12,0	32,0	49,0	50,0	46,0	10,0	27,1	M10x1	130	MHC-CAT040-12-050-3-0-A	31345227	
40	14,0	32,0	49,0	50,0	46,0	10,0	27,1	M10x1	240	MHC-CAT040-14-050-3-0-A	31374694	
40	16,0	38,0	49,0	64,5	49,0	10,0	41,6	M12x1	350	MHC-CAT040-16-065-3-0-A	31345228	
40	18,0	38,0	49,0	64,5	49,0	10,0	41,6	M12x1	430	MHC-CAT040-18-065-3-0-A	31374695	
40	20,0	38,0	49,0	64,5	51,0	10,0	41,6	M16x1	520	MHC-CAT040-20-065-3-0-A	31345229	

* Permissible transmittable torque.

Dimensions in mm.

Application: For clamping tools with smooth cylindrical shanks to DIN 1835 Form A, DIN 6535 Form HA as well as with recesses to DIN 1835 Form B, E and DIN 6535 Form HB, HE directly and with reducing sleeve in the clamping diameter. The clamping diameter is designed for a shank tolerance h6.

Scope of delivery: With length adjustment screw, without coolant tube.

Design: Highest tool life and production quality when using smooth shanks according to DIN 1835 form A and DIN 6535 form HA.

With a length of 2.5xD (max. 50 mm) concentricity 3 μ m. When using cylindrical shanks

with inclined clamping surface (form E and form HE), the accuracy may be impaired.

Torque transmission perfectly tailored to your application.

Note: Coolant supply via central through hole. Coolant tubes, code carriers, reducing sleeves for reducing the clamping diameter (when using the reducing sleeve, an impairment of the accuracy is possible) see category accessories, spare parts and measuring equipment.

Length adjustment screws available on request.

Balance quality: G 2.5 at 25,000 min^{-1} as delivered.

UNIQ® DReaM Chuck, 4.5°

With axial tool length adjustment, clamping insertion in the collar
Shank HSK-A according to DIN 69893-1

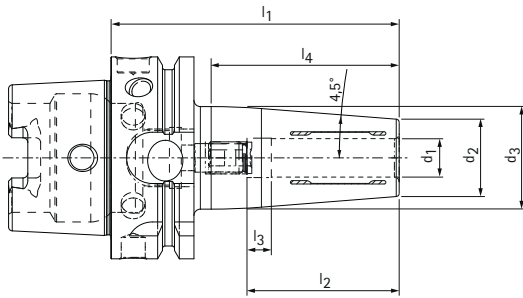

HSK-A	Dimensions							G	Torque* [Nm]	Specification	Order No.	Availability
	d1	d2	d3	l1	l2	l3	l4					
63	6,0	21,0	27,0	80,0	37,0	10,0	48,9	M5	18	MHC-HSK-A063-06-080-1-0-A	31270515	in stock
63	6,0	21,0	27,0	120,0	37,0	10,0	48,9	M5	18	MHC-HSK-A063-06-120-1-0-A	31441122	
63	6,0	21,0	27,0	160,0	37,0	10,0	48,9	M5	18	MHC-HSK-A063-06-160-1-0-A	31499983	
63	8,0	21,0	27,0	80,0	37,0	10,0	48,9	M6	35	MHC-HSK-A063-08-080-1-0-A	31270525	
63	8,0	21,0	27,0	120,0	37,0	10,0	48,9	M6	35	MHC-HSK-A063-08-120-1-0-A	31441123	
63	8,0	21,0	27,0	160,0	37,0	10,0	48,9	M8x1	35	MHC-HSK-A063-08-160-1-0-A	31499984	
63	10,0	24,0	32,0	85,0	41,0	10,0	53,7	M8x1	60	MHC-HSK-A063-10-085-1-0-A	31270550	
63	10,0	24,0	32,0	120,0	41,0	10,0	61,6	M8x1	60	MHC-HSK-A063-10-120-1-0-A	31441124	
63	10,0	24,0	32,0	160,0	41,0	10,0	61,6	M8x1	60	MHC-HSK-A063-10-160-1-0-A	31499985	
63	12,0	24,0	32,0	90,0	46,0	10,0	58,6	M10x1	90	MHC-HSK-A063-12-090-1-0-A	31229439	
63	12,0	24,0	32,0	120,0	46,0	10,0	61,6	M10x1	90	MHC-HSK-A063-12-120-1-0-A	31441125	
63	12,0	24,0	32,0	160,0	46,0	10,0	61,6	M10x1	90	MHC-HSK-A063-12-160-1-0-A	31499986	
63	14,0	27,0	34,0	90,0	46,0	10,0	57,2	M10x1	130	MHC-HSK-A063-14-090-1-0-A	31375071	
63	14,0	27,0	34,0	120,0	46,0	10,0	56,2	M10x1	130	MHC-HSK-A063-14-120-1-0-A	31441126	
63	14,0	27,0	34,0	160,0	46,0	10,0	56,2	M10x1	130	MHC-HSK-A063-14-160-1-0-A	31499987	
63	16,0	27,0	34,0	95,0	49,0	10,0	63,1	M12x1	200	MHC-HSK-A063-16-095-1-0-A	31270555	
63	16,0	27,0	34,0	120,0	49,0	10,0	56,2	M12x1	200	MHC-HSK-A063-16-120-1-0-A	31441127	
63	16,0	27,0	34,0	160,0	49,0	10,0	56,2	M12x1	200	MHC-HSK-A063-16-160-1-0-A	31499988	
63	18,0	33,0	42,0	95,0	49,0	10,0	63,0	M12x1	250	MHC-HSK-A063-18-095-1-0-A	31375072	
63	18,0	33,0	42,0	120,0	49,0	10,0	68,9	M12x1	250	MHC-HSK-A063-18-120-1-0-A	31441128	
63	18,0	33,0	42,0	160,0	49,0	10,0	68,9	M12x1	250	MHC-HSK-A063-18-160-1-0-A	31499989	
63	20,0	33,0	42,0	100,0	51,0	10,0	68,9	M16x1	330	MHC-HSK-A063-20-100-1-0-A	31229440	
63	20,0	33,0	42,0	120,0	51,0	10,0	68,9	M16x1	330	MHC-HSK-A063-20-120-1-0-A	31441129	
63	20,0	33,0	42,0	160,0	51,0	10,0	68,9	M16x1	330	MHC-HSK-A063-20-160-1-0-A	31500040	
63	25,0	44,0	52,5	115,0	57,0	10,0	85,4	M16x1	500	MHC-HSK-A063-25-115-1-0-A	31396186	
63	25,0	44,0	52,5	160,0	57,0	10,0	85,4	M16x1	500	MHC-HSK-A063-25-160-1-0-A	31504685	
63	32,0	44,0	52,5	120,0	61,0	10,0	90,1	M16x1	650	MHC-HSK-A063-32-120-1-0-A	31396187	
63	32,0	44,0	52,5	160,0	61,0	10,0	90,1	M16x1	650	MHC-HSK-A063-32-160-1-0-A	31504687	

UNIQ® DReaM Chuck, 4.5° | With axial tool length adjustment, clamping insertion in the collar, shank HSK-A according to DIN 69893-1

HSK-A	Dimensions							G	Torque * [Nm]	Specification	Order No.	Availability
	d ₁	d ₂	d ₃	l ₁	l ₂	l ₃	l ₄					
100	6,0	21,0	27,0	85,0	37,0	10,0	38,7	M5	18	MHC-HSK-A100-06-085-1-0-A	31344789	in stock
100	6,0	21,0	27,0	120,0	37,0	10,0	48,9	M5	18	MHC-HSK-A100-06-120-1-0-A	31496256	
100	6,0	21,0	27,0	160,0	37,0	10,0	48,9	M5	18	MHC-HSK-A100-06-160-1-0-A	31500057	
100	8,0	21,0	27,0	85,0	37,0	10,0	38,7	M6	35	MHC-HSK-A100-08-085-1-0-A	31344860	
100	8,0	21,0	27,0	120,0	37,0	10,0	48,9	M6	35	MHC-HSK-A100-08-120-1-0-A	31496257	
100	8,0	21,0	27,0	160,0	37,0	10,0	48,9	M6	35	MHC-HSK-A100-08-160-1-0-A	31500058	
100	10,0	24,0	32,0	90,0	41,0	10,0	53,7	M8x1	60	MHC-HSK-A100-10-090-1-0-A	31344862	
100	10,0	24,0	32,0	120,0	41,0	10,0	61,6	M8x1	60	MHC-HSK-A100-10-120-1-0-A	31496258	
100	10,0	24,0	32,0	160,0	41,0	10,0	61,6	M8x1	60	MHC-HSK-A100-10-160-1-0-A	31500059	
100	12,0	24,0	32,0	95,0	46,0	10,0	58,6	M10x1	90	MHC-HSK-A100-12-095-1-0-A	31344863	
100	12,0	24,0	32,0	120,0	46,0	10,0	61,6	M10x1	90	MHC-HSK-A100-12-120-1-0-A	31496259	
100	12,0	24,0	32,0	160,0	46,0	10,0	61,6	M10x1	90	MHC-HSK-A100-12-160-1-0-A	31500060	
100	14,0	27,0	34,0	95,0	46,0	10,0	57,2	M10x1	130	MHC-HSK-A100-14-095-1-0-A	31344864	
100	14,0	27,0	34,0	120,0	46,0	10,0	56,2	M10x1	130	MHC-HSK-A100-14-120-1-0-A	31496300	
100	14,0	27,0	34,0	160,0	46,0	10,0	56,2	M10x1	130	MHC-HSK-A100-14-160-1-0-A	31500061	
100	16,0	27,0	34,0	100,0	49,0	10,0	63,1	M12x1	200	MHC-HSK-A100-16-100-1-0-A	31344865	
100	16,0	27,0	34,0	120,0	49,0	10,0	56,2	M12x1	200	MHC-HSK-A100-16-120-1-0-A	31496301	
100	16,0	27,0	34,0	160,0	49,0	10,0	56,2	M12x1	200	MHC-HSK-A100-16-160-1-0-A	31500062	
100	18,0	33,0	42,0	100,0	49,0	10,0	63,0	M12x1	250	MHC-HSK-A100-18-100-1-0-A	31344866	
100	18,0	33,0	42,0	120,0	49,0	10,0	68,9	M12x1	250	MHC-HSK-A100-18-120-1-0-A	31496302	
100	18,0	33,0	42,0	160,0	49,0	10,0	68,9	M12x1	250	MHC-HSK-A100-18-160-1-0-A	31500063	
100	20,0	33,0	42,0	105,0	51,0	10,0	68,9	M16x1	330	MHC-HSK-A100-20-105-1-0-A	31344867	
100	20,0	33,0	42,0	120,0	51,0	10,0	68,9	M16x1	330	MHC-HSK-A100-20-120-1-0-A	31496303	
100	20,0	33,0	42,0	160,0	51,0	10,0	68,9	M16x1	330	MHC-HSK-A100-20-160-1-0-A	31500064	
100	25,0	44,0	53,0	115,0	57,0	10,0	80,7	M16x1	500	MHC-HSK-A100-25-115-1-0-A	31344868	
100	25,0	44,0	53,0	160,0	57,0	10,0	88,6	M16x1	500	MHC-HSK-A100-25-160-1-0-A	31505294	
100	32,0	44,0	53,0	120,0	61,0	10,0	84,6	M16x1	650	MHC-HSK-A100-32-120-1-0-A	31344869	
100	32,0	44,0	53,0	160,0	61,0	10,0	93,3	M16x1	650	MHC-HSK-A100-32-160-1-0-A	31505295	

* Permissible transmittable torque.

Dimensions in mm.

Application: For clamping tools with smooth cylindrical shanks to DIN 1835 Form A, DIN 6535 Form HA as well as with recesses to DIN 1835 Form B, E and DIN 6535 Form HB, HE directly and with reducing sleeve in the clamping diameter. The clamping diameter is designed for a shank tolerance h6.

Scope of delivery: With length adjustment screw, without coolant tube.

Design: Highest tool life and production quality when using plain shanks according to DIN 1835 form A and DIN 6535 form HA. With a cantilever length of 2.5xD (max. 50 mm) concentricity 3 µm. When using cylindrical shanks with inclined clamping surface

(form E and form HE), the accuracy may be impaired. Torque transmission perfectly tailored to your application.

Note: Coolant supply via central through hole. Coolant tubes, code carriers, reducing sleeves for reducing the clamping diameter (when using the reducing sleeve, an impairment of the accuracy is possible) see category accessories, spare parts and measuring equipment. Length adjustment screws available on request.

Balance quality: G 2.5 at 25,000 min⁻¹ as delivered.

UNIQ® DReaM Chuck, 4.5°

With axial tool length adjustment, clamping insertion in the collar
Shank hollow shank taper A according to ISO 7388-1 form AD/AF

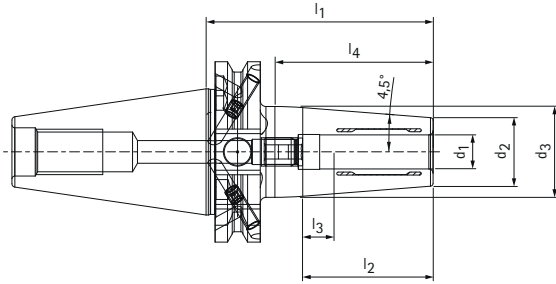

SK	Dimensions								G	Torque* [Nm]	Specification	Order No.	Availability
	d ₁	d ₂	d ₃	d ₄		l ₂	l ₃	l ₄					
40	6,0	21,0	27,0	-	80,0	37,0	10,0	55,7	M5	18	MHC-SK040-06-080-3-0-A	31344880	in stock
40	6,0	21,0	27,0	-	120,0	37,0	10,0	48,9	M5	18	MHC-SK040-06-120-3-0-A	31441418	
40	8,0	21,0	27,0	-	80,0	37,0	10,0	55,7	M6	35	MHC-SK040-08-080-3-0-A	31344881	
40	8,0	21,0	27,0	-	120,0	37,0	10,0	48,9	M6	35	MHC-SK040-08-120-3-0-A	31441419	
40	10,0	24,0	32,0	-	80,0	41,0	10,0	55,7	M8x1	60	MHC-SK040-10-080-3-0-A	31344882	
40	10,0	24,0	32,0	-	120,0	41,0	10,0	61,6	M8x1	60	MHC-SK040-10-120-3-0-A	31441490	
40	12,0	24,0	32,0	-	80,0	46,0	10,0	55,7	M10x1	90	MHC-SK040-12-080-3-0-A	31344883	
40	12,0	24,0	32,0	-	120,0	46,0	10,0	61,6	M10x1	90	MHC-SK040-12-120-3-0-A	31441491	
40	14,0	27,0	34,0	-	80,0	46,0	10,0	55,8	M10x1	130	MHC-SK040-14-080-3-0-A	31375087	
40	14,0	27,0	34,0	-	120,0	46,0	10,0	56,2	M10x1	130	MHC-SK040-14-120-3-0-A	31441492	
40	16,0	27,0	34,0	-	80,0	49,0	10,0	55,8	M12x1	200	MHC-SK040-16-080-3-0-A	31344884	
40	16,0	27,0	34,0	-	120,0	49,0	10,0	56,2	M12x1	200	MHC-SK040-16-120-3-0-A	31441493	
40	18,0	33,0	42,0	-	80,0	49,0	10,0	57,2	M12x1	250	MHC-SK040-18-080-3-0-A	31375088	
40	18,0	33,0	42,0	-	120,0	49,0	10,0	68,9	M12x1	250	MHC-SK040-18-120-3-0-A	31441494	
40	20,0	33,0	42,0	-	80,0	51,0	10,0	57,2	M16x1	330	MHC-SK040-20-080-3-0-A	31344885	
40	20,0	33,0	42,0	-	120,0	51,0	10,0	68,9	M16x1	330	MHC-SK040-20-120-3-0-A	31441495	
40	25,0	44,0	53,0	49,0	100,0	57,0	10,0	58,7	M10x1	500	MHC-SK040-25-100-3-0-A	31396194	
40	32,0	44,0	53,0	-	100,0	61,0	10,0	58,3	M10x1	650	MHC-SK040-32-100-3-0-A	31396195	

* Permissible transmittable torque.

Dimensions in mm.

Application: For clamping tools with smooth cylindrical shanks to DIN 1835 Form A, DIN 6535 Form HA as well as with recesses to DIN 1835 Form B, E and DIN 6535 Form HB, HE directly and with reducing sleeve in the clamping diameter. The clamping diameter is designed for a shank tolerance h6.

Scope of delivery: With length adjustment screw, without coolant tube.

Design: Highest tool life and production quality when using smooth shanks according to DIN 1835 form A and DIN 6535 form HA.

With a length of 2.5xD (max. 50 mm) concentricity 3 µm. When using cylindrical shanks

with inclined clamping surface (form E and form HE), the accuracy may be impaired.

Torque transmission perfectly tailored to your application.

Note: Coolant supply via central through hole. Coolant tubes, code carriers, reducing sleeves for reducing the clamping diameter (when using the reducing sleeve, an impairment of the accuracy is possible) see category accessories, spare parts and measuring equipment. Length adjustment screws available on request.

Balance quality: G 2.5 at 25,000 min⁻¹ as delivered.

UNIQ® DReaM Chuck, 4.5°

With axial tool length adjustment, clamping insertion in the collar
Shank BT according to ISO 7388-2 form JD/JF (JIS B 6339)

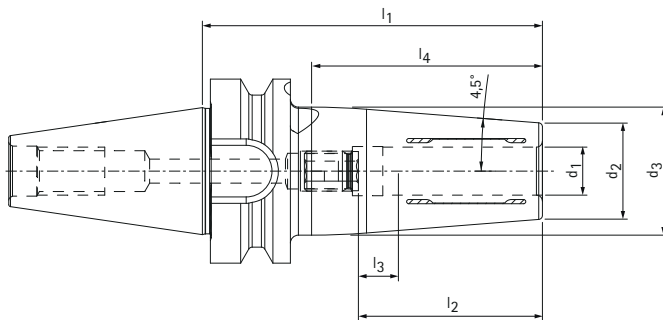

BT	Dimensions							G	Torque* [Nm]	Specification	Order No.	Availability
	d ₁	d ₂	d ₃	l ₁	l ₂	l ₃	l ₄					
30**	6,0	21,0	27,0	85,0	37,0	10,0	57,7	M5	18	MHC-BT030-06-085-1-0-A	31280360	in stock
30**	8,0	21,0	27,0	85,0	37,0	10,0	57,7	M6	35	MHC-BT030-08-085-1-0-A	31280361	
30**	10,0	24,0	32,0	85,0	41,0	10,0	57,7	M8x1	60	MHC-BT030-10-085-1-0-A	31280362	
30**	12,0	24,0	32,0	85,0	46,0	10,0	57,7	M10x1	90	MHC-BT030-12-085-1-0-A	31280365	
30**	14,0	27,0	34,0	85,0	46,0	10,0	57,2	M10x1	130	MHC-BT030-14-085-1-0-A	31375079	
30**	16,0	27,0	34,0	85,0	49,0	10,0	57,2	M10x1	200	MHC-BT030-16-085-1-0-A	31280366	
30**	18,0	33,0	42,0	85,0	49,0	10,0	57,5	M12x1	250	MHC-BT030-18-085-1-0-A	31375080	
30**	20,0	33,0	42,0	85,0	51,0	10,0	57,5	M10x1	330	MHC-BT030-20-085-1-0-A	31280367	
40	6,0	21,0	27,0	90,0	37,0	10,0	57,7	M5	18	MHC-BT040-06-090-3-0-A	31344904	in stock
40	6,0	21,0	27,0	120,0	37,0	10,0	48,9	M5	18	MHC-BT040-06-120-3-0-A	31496324	
40	8,0	21,0	27,0	90,0	37,0	10,0	57,7	M6	35	MHC-BT040-08-090-3-0-A	31344905	
40	8,0	21,0	27,0	120,0	37,0	10,0	48,9	M6	35	MHC-BT040-08-120-3-0-A	31496325	
40	10,0	24,0	32,0	90,0	41,0	10,0	57,7	M8x1	60	MHC-BT040-10-090-3-0-A	31344906	
40	10,0	24,0	32,0	120,0	41,0	10,0	61,6	M8x1	60	MHC-BT040-10-120-3-0-A	31496326	
40	12,0	24,0	32,0	90,0	46,0	10,0	57,7	M10x1	90	MHC-BT040-12-090-3-0-A	31344907	
40	12,0	24,0	32,0	120,0	46,0	10,0	61,6	M10x1	90	MHC-BT040-12-120-3-0-A	31496327	
40	14,0	27,0	34,0	90,0	46,0	10,0	57,2	M10x1	130	MHC-BT040-14-090-3-0-A	31396128	
40	14,0	27,0	34,0	120,0	46,0	10,0	56,2	M10x1	130	MHC-BT040-14-120-3-0-A	31496328	
40	16,0	27,0	34,0	90,0	49,0	10,0	57,2	M12x1	200	MHC-BT040-16-090-3-0-A	31344908	
40	16,0	27,0	34,0	120,0	49,0	10,0	56,2	M12x1	200	MHC-BT040-16-120-3-0-A	31496329	
40	18,0	33,0	42,0	90,0	49,0	10,0	57,5	M12x1	250	MHC-BT040-18-090-3-0-A	31396129	
40	18,0	33,0	42,0	120,0	49,0	10,0	68,9	M12x1	250	MHC-BT040-18-120-3-0-A	31496330	
40	20,0	33,0	42,0	90,0	51,0	10,0	57,5	M16x1	330	MHC-BT040-20-090-3-0-A	31344909	
40	20,0	33,0	42,0	120,0	51,0	10,0	68,9	M16x1	330	MHC-BT040-20-120-3-0-A	31496331	
40	25,0	44,0	53,0	100,0	57,0	10,0	67,9	M16x1	500	MHC-BT040-25-100-3-0-A	31396140	
40	32,0	44,0	53,0	100,0	61,0	10,0	67,9	M16x1	650	MHC-BT040-32-100-3-0-A	31396141	

* Permissible transmittable torque.

** Design: Steep taper size is not available in combination design JD/JF

Dimensions in mm.

Application: For clamping tools with smooth cylindrical shanks to DIN 1835 Form A, DIN 6535 Form HA as well as with recesses to DIN 1835 Form B, E and DIN 6535 Form HB, HE directly and with reducing sleeve in the clamping diameter. The clamping diameter is designed for a shank tolerance h6.

Scope of delivery: With length adjustment screw, without tightening bolt.

Design: Highest tool life and manufacturing quality when using smooth shanks according to DIN 1835 form A and DIN 6535 form HA. With an overhang length of 2.5xD

(max. 50 mm) concentricity accuracy 3 µm. When using cylindrical shanks with inclined clamping surface (form E and form HE), the accuracy may be impaired. Torque transmission perfectly tailored to your application.

Note: Coolant supply via central through hole. Tightening bolts, reducing sleeves for reducing the clamping diameter. (When using the reducing sleeve, accuracy may be impaired) see category accessories and spare parts. Length adjustment screws available on request. Balance quality: G 2.5 at 25,000 min⁻¹ as delivered.

UNIQ® DReaM Chuck, 4.5°

With axial tool length adjustment, clamping insertion in the collar
Shank "CAT" according to ASME B5.50-1994

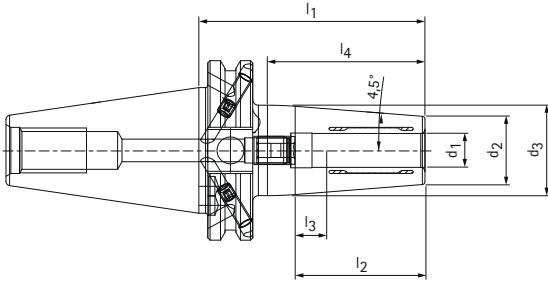

CAT	Dimensions							G	Torque * [Nm]	Specification	Order No.	Availability
	d ₁	d ₂	d ₃	l ₁	l ₂	l ₃	l ₄					
40	6,0	21,0	27,0	80,0	37,0	10,0	55,7	M5	18	MHC-CAT040-06-080-3-0-A	31344892	in stock
40	8,0	21,0	27,0	80,0	37,0	10,0	55,7	M6	35	MHC-CAT040-08-080-3-0-A	31344893	
40	10,0	24,0	32,0	80,0	41,0	10,0	55,7	M8x1	60	MHC-CAT040-10-080-3-0-A	31344894	
40	12,0	24,0	32,0	80,0	46,0	10,0	55,7	M10x1	90	MHC-CAT040-12-080-3-0-A	31344895	
40	14,0	27,0	34,0	80,0	46,0	10,0	55,8	M10x1	130	MHC-CAT040-14-080-3-0-A	31375095	
40	16,0	27,0	34,0	80,0	49,0	10,0	55,8	M12x1	200	MHC-CAT040-16-080-3-0-A	31344896	
40	18,0	33,0	42,0	80,0	49,0	10,0	57,2	M12x1	250	MHC-CAT040-18-080-3-0-A	31375096	
40	20,0	33,0	42,0	80,0	51,0	10,0	57,2	M16x1	330	MHC-CAT040-20-080-3-0-A	31344897	

* Permissible transmittable torque.

Dimensions in mm.

Application: For clamping tools with smooth cylindrical shanks to DIN 1835 Form A, DIN 6535 Form HA as well as with recesses to DIN 1835 Form B, E and DIN 6535 Form HB, HE directly and with reducing sleeve in the clamping diameter. The clamping diameter is designed for a shank tolerance h6.

Scope of delivery: With length adjustment screw, without coolant tube.

Design: Highest tool life and production quality when using smooth shanks according to DIN 1835 form A and DIN 6535 form HA.

With a length of 2.5xD (max. 50 mm) concentricity 3 µm. When using cylindrical shanks

with inclined clamping surface (form E and form HE), the accuracy may be impaired. Torque transmission perfectly tailored to your application.

Note: Coolant supply via central through hole. Coolant tubes, code carriers, reducing sleeves for reducing the clamping diameter (when using the reducing sleeve, an impairment of the accuracy is possible) see category accessories, spare parts and measuring equipment. Length adjustment screws available on request.

Balance quality: G 2.5 at 25,000 min⁻¹ as delivered.



Discover tool and service solutions now that will move you forward:

BORE MACHINING

REAMING | FINE BORING

DRILLING FROM SOLID | BORING | COUNTERSINKING

MILLING

CLAMPING

TURNING

ACTUATING

SETTING | MEASURING | DISPENSING

SERVICES

FOLLOW US

