

ETP HYDRO-FIX SBW®

Hydraulic high precision clamping unit

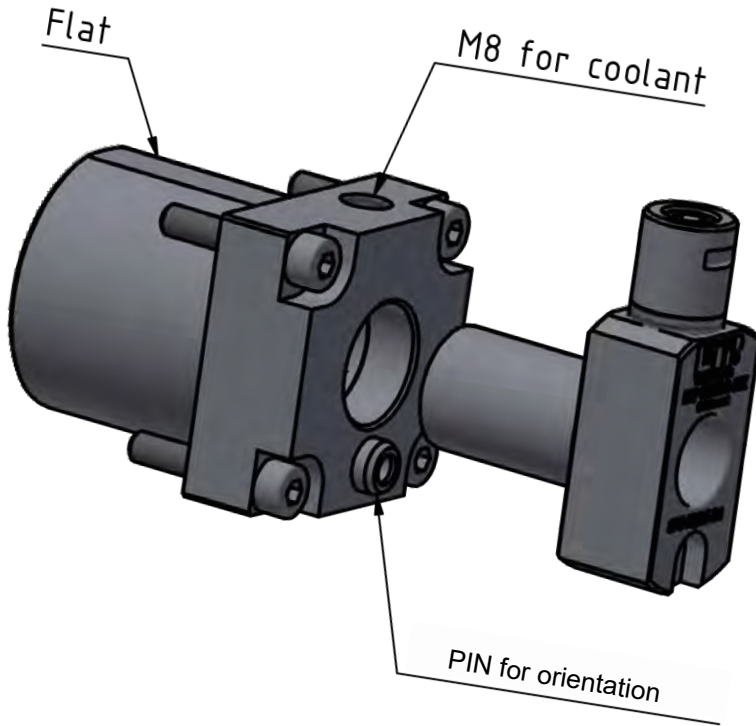

**WITH
COOLANT
THROUGH**

Excellent for static SWISS back operations

ETP HYDRO-FIX SBW clamping units are excellent for static back operations such as drilling, reaming and boring. With the one screw fix system it is quick and easy to handle. Precision hydraulic tool centering is achieved and therefore the tool life and setup time is improved. The clamping unit allows for larger/deeper drilling, quick tool changes, absorbs/reduces vibration, improves surface quality and best of all: **Increases your productivity!**

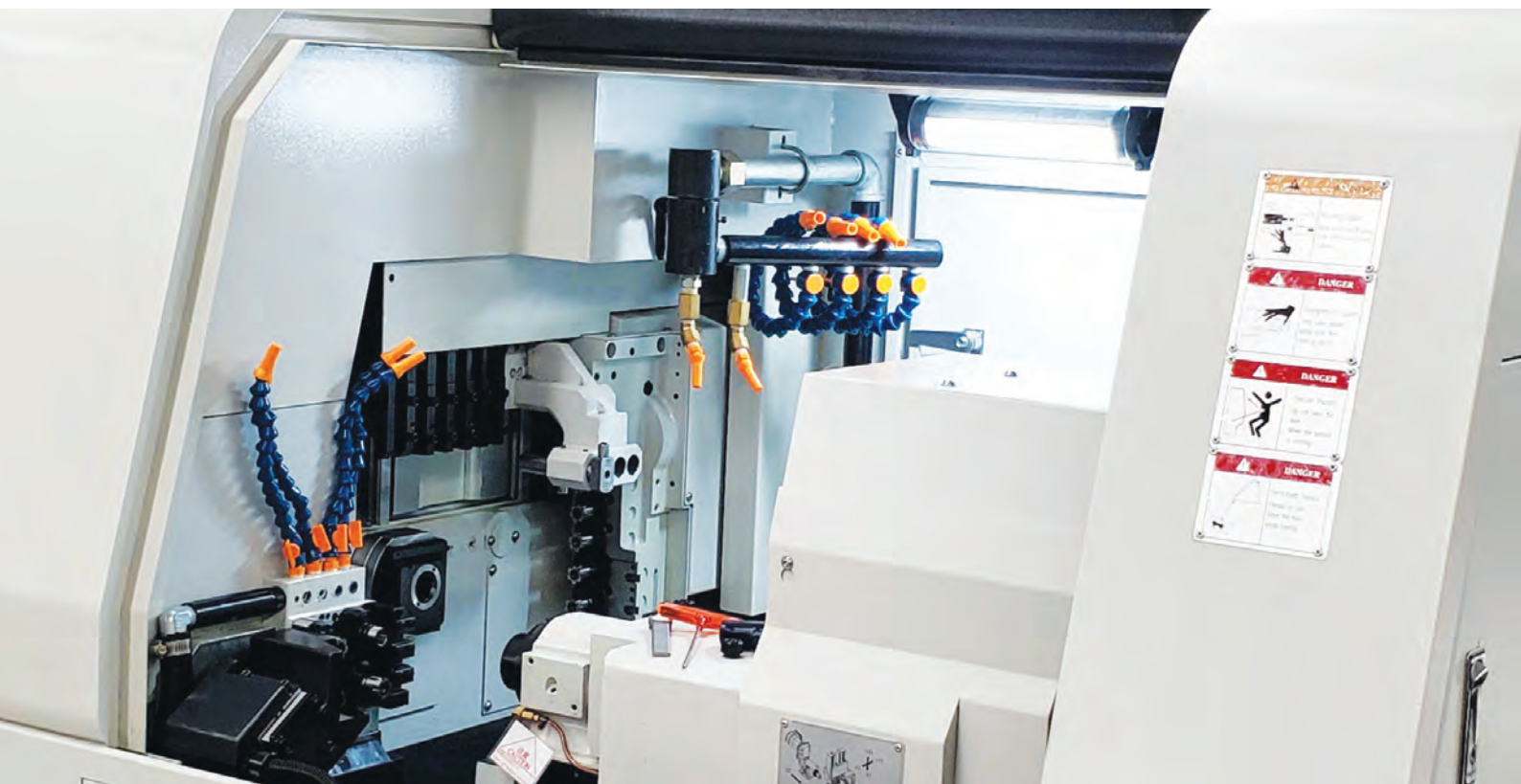

ETP HYDRO-FIX SBW[®]

Hydraulic high precision clamping unit

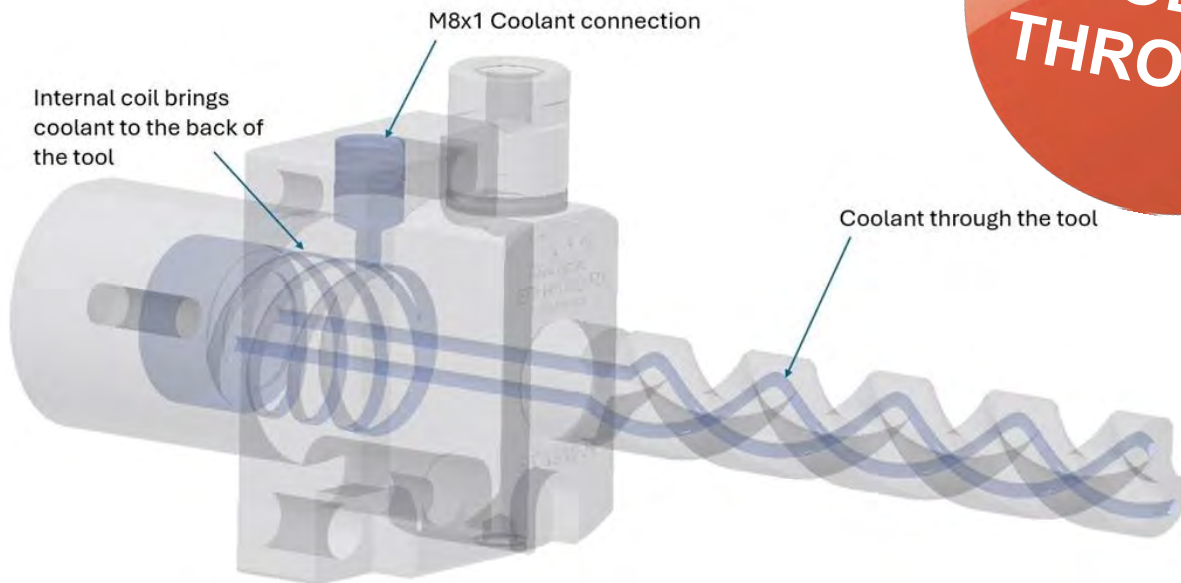

ETP SWISS BACKWORKING APPLICATION

1 . FIND YOUR MACHINE

2 . CHOOSE SUITABLE ETP HYDRO-FIX SLEEVE



1. MACHINE		2. CHOOSE ETP HYDRO-FIX SLEEVE						
Machine Mfg.	Machine type	670010	670020	670030	670040	670050	670060	670070
STAR	SB20	•	•					
	SR20	•	•					
	SR20J	•	•					
	SR32J	•	•					
	SR32JII	•	•					
	SR38	•	•					
	SX38			•				
CITIZEN	L12				•			
	L20					•		
	L32X						•	•



information:

*) Tool/toolbar shank h6 or h7 can be used.
Adjustment screw included in shipment.
Can also be ordered separately as spare part.
M5x0.8-16 Part no. S041



Accessories:

Use preset Torque wrench to ensure correct mounting of tools.
6 Nm - Part no. 19055



ETP HYDRO-FIX can be used with reduction sleeves.



670010 - ETP HYDRO-FIX SBW-12/22-25 F1

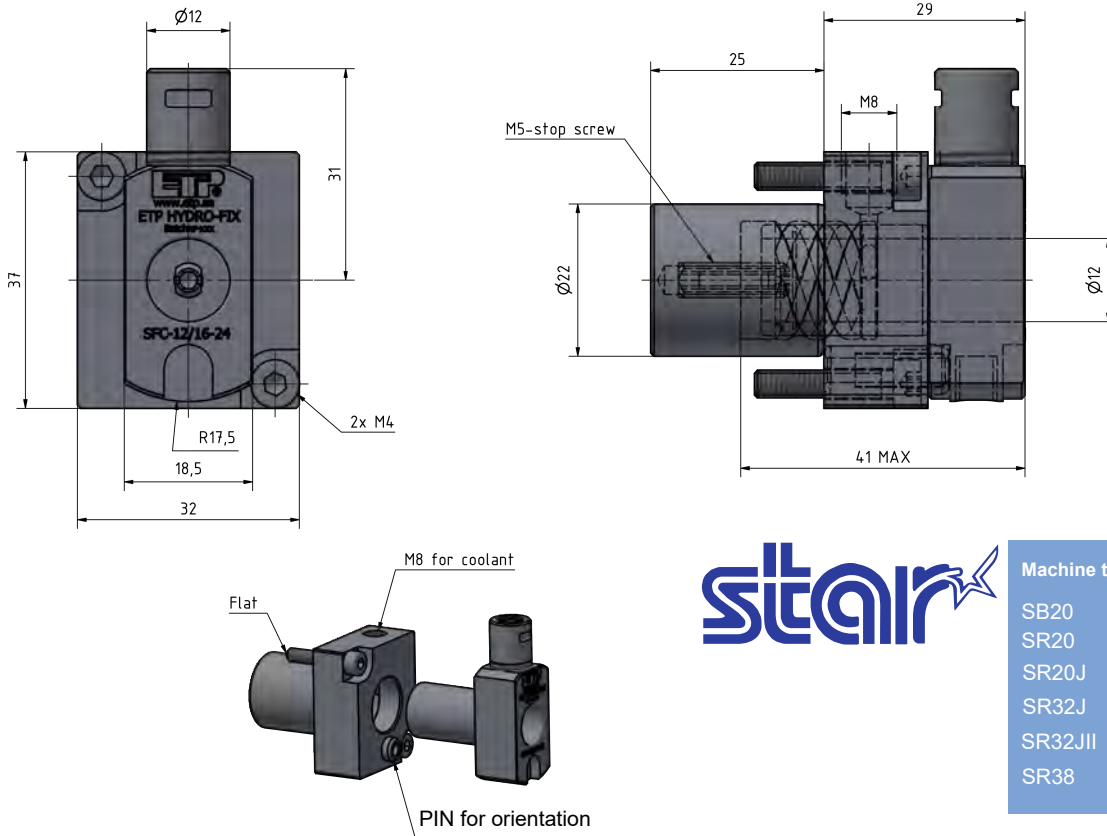

Machine type

- SB20
- SR20
- SR20J
- SR32J
- SR32JII
- SR38

670020 - ETP HYDRO-FIX SBW-12/22-25 F2

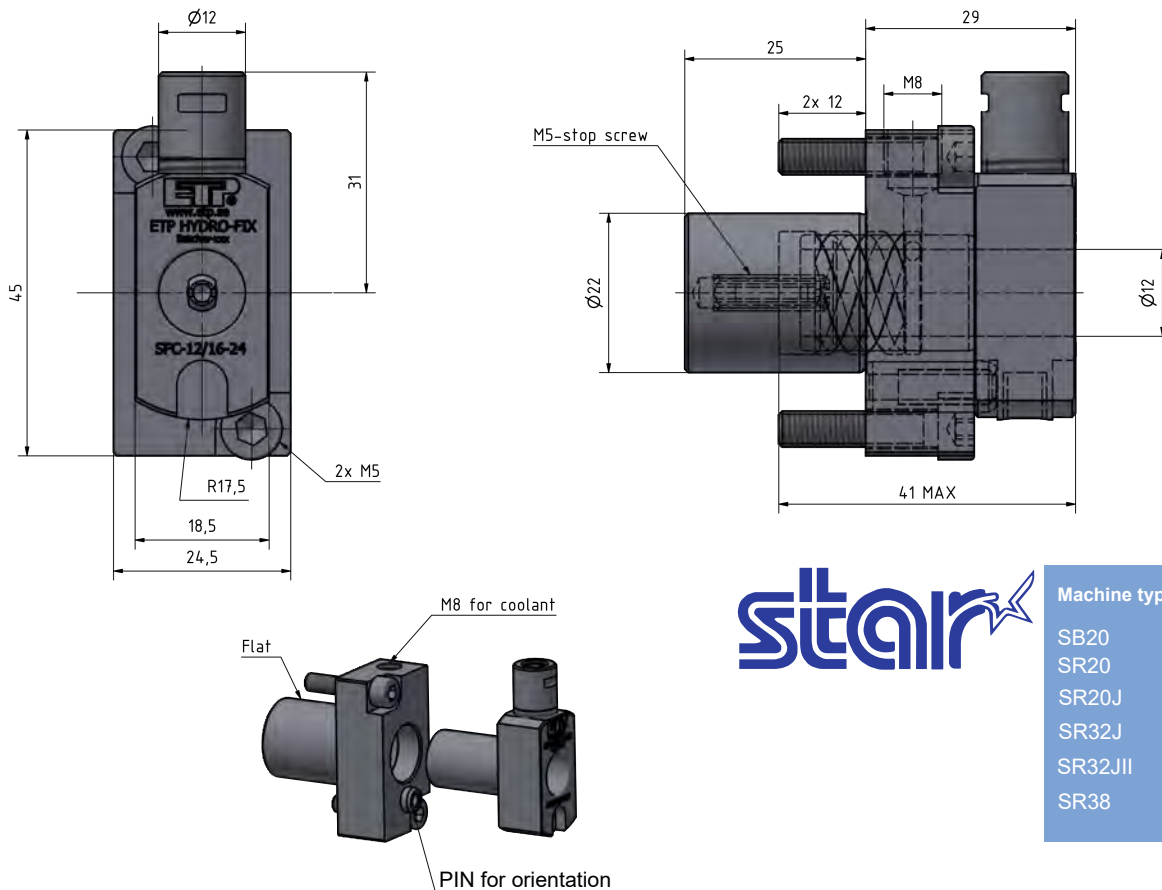

Machine type

- SB20
- SR20
- SR20J
- SR32J
- SR32JII
- SR38

670030 - ETP HYDRO-FIX SBW-12/34-30 F1

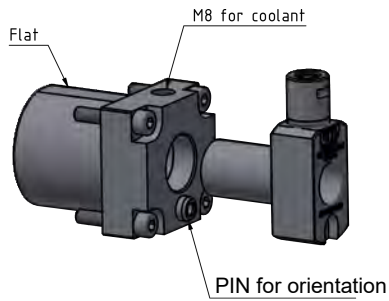
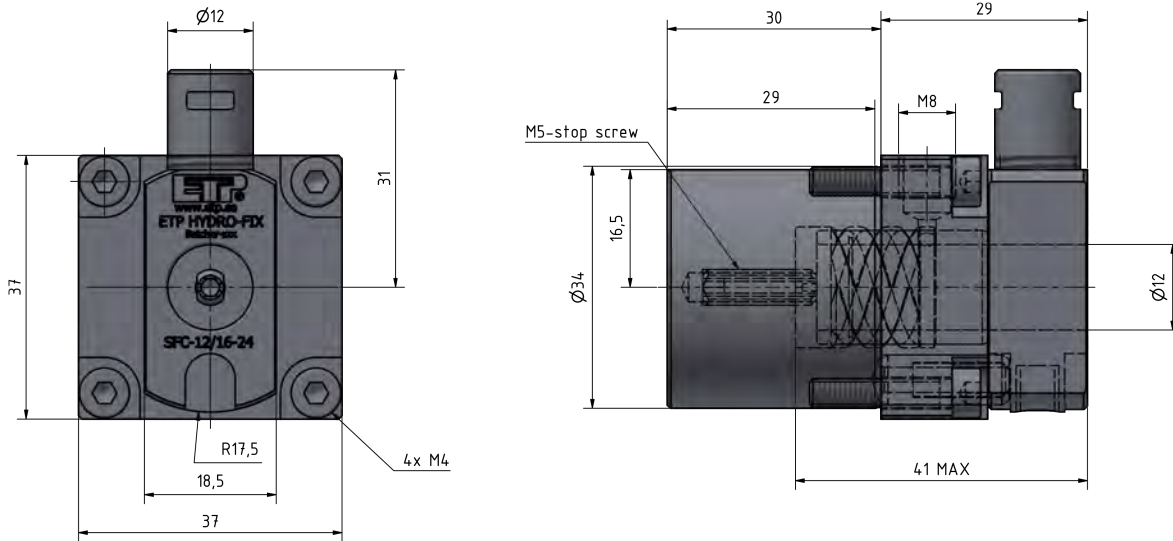

Machine type
SX38

670040 - ETP HYDRO-FIX SBW-12/25-33 F1

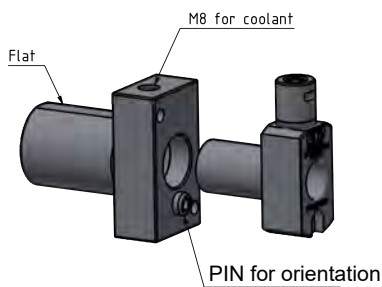
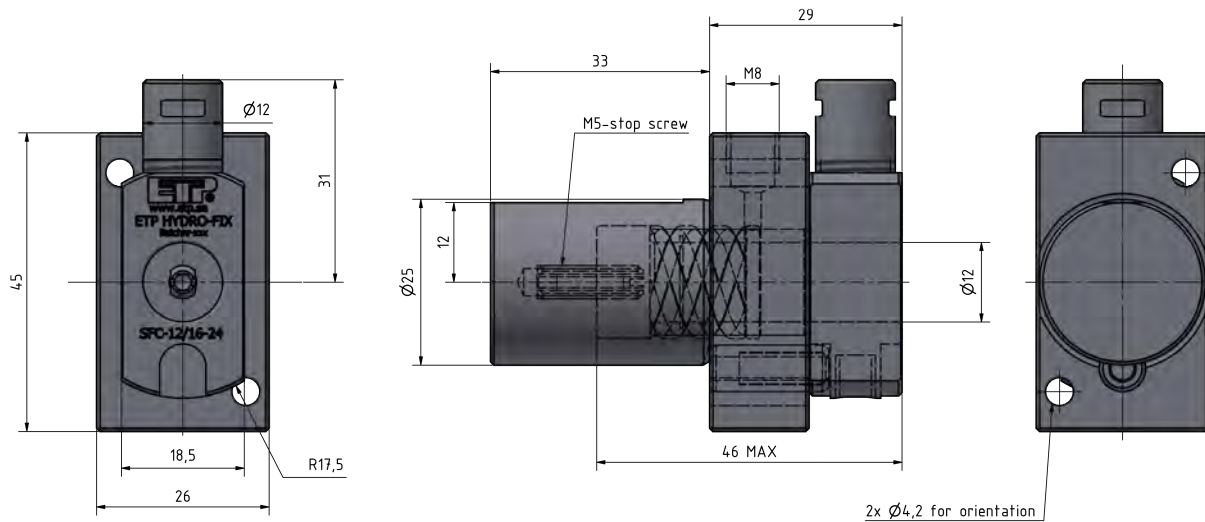

Machine type
L12

670050 - ETP HYDRO-FIX SBW-12/25-30 F1

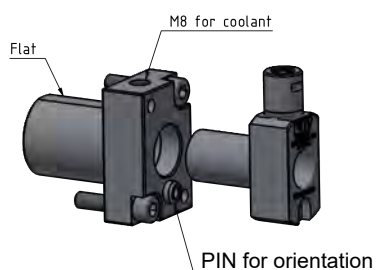
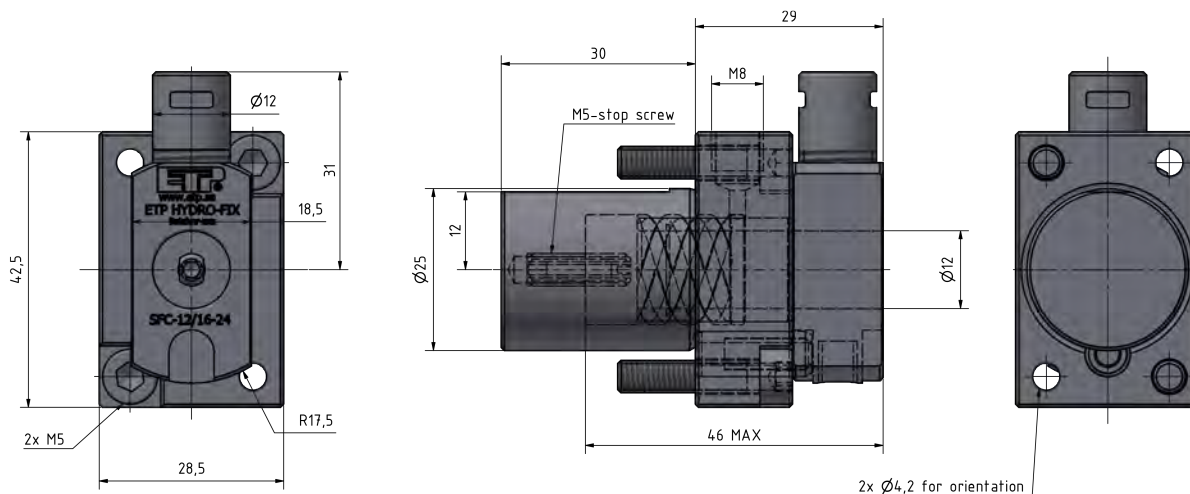

Citizen

Machine type
L20

670060 - ETP HYDRO-FIX SBW-12/31-36 F1

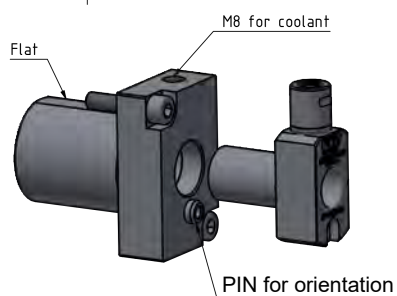
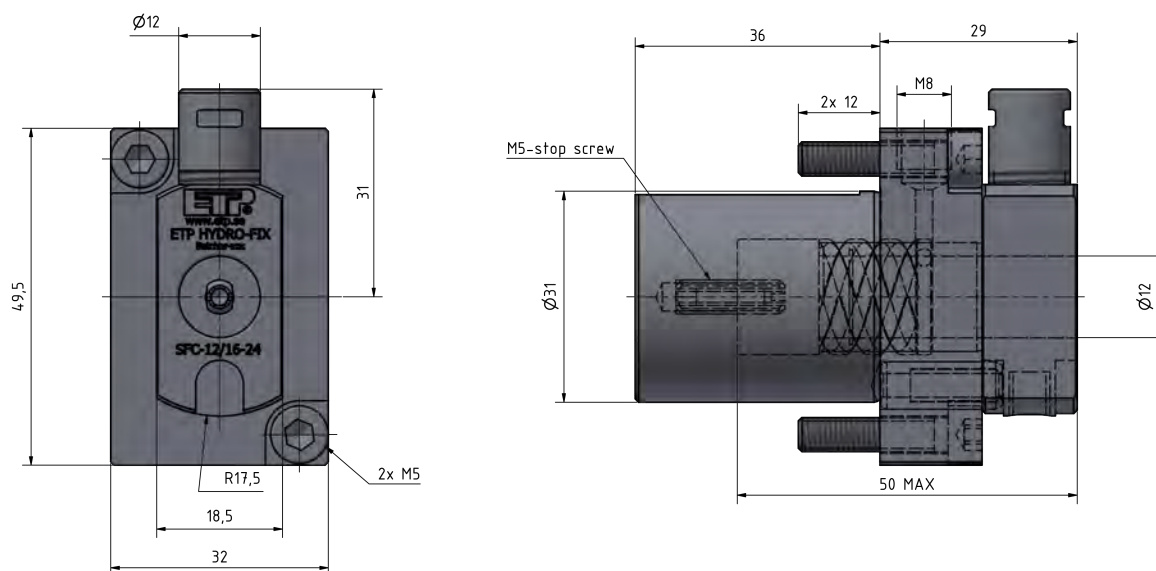

Citizen

Machine type
L32X

670070 - ETP HYDRO-FIX SBW-20/31-36 F1

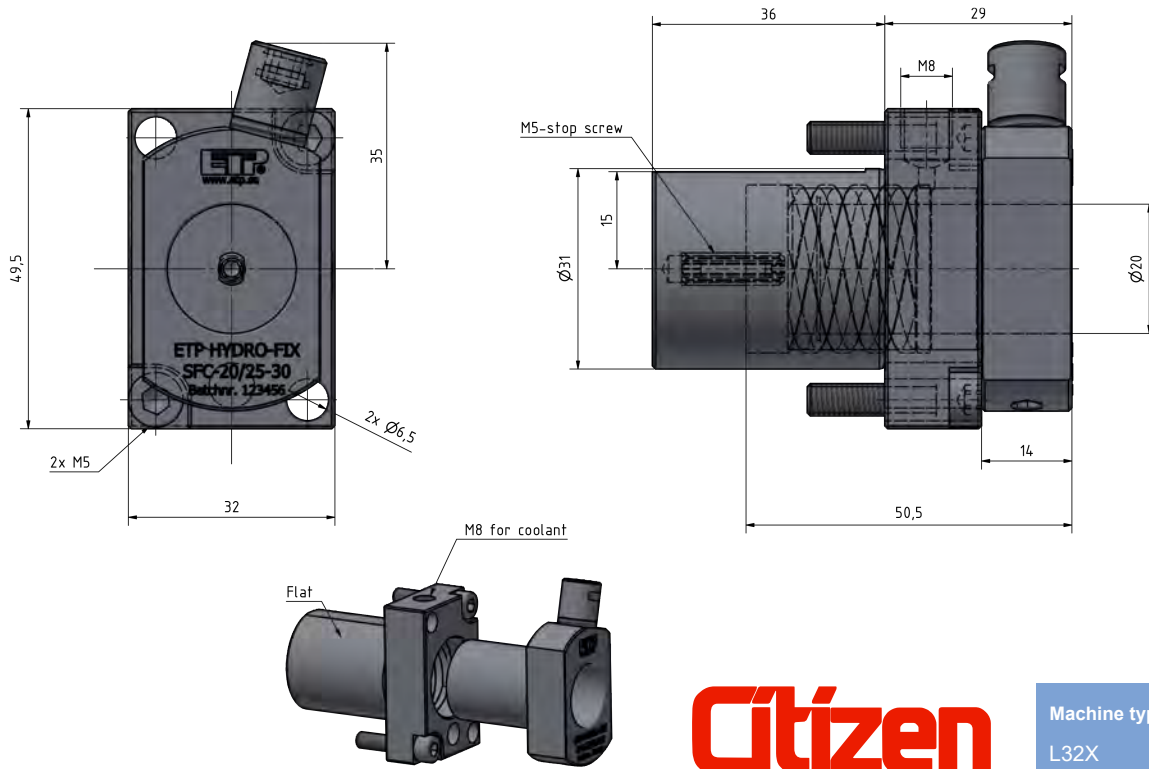

Citizen

Machine type
L32X



Box 1120, SE-581 11 Linköping, Sweden
Tel. +46 (0)13 24 71 00
E-mail: info@etp.se, Internet: www.etp.se